

MICRO AIR RP6-3 DUST COLLECTOR

Specifications and Technical Data

TYPICAL APPLICATIONS:

- WELD SMOKE AND FUMES
- GRINDING / POLISHING DUST
- POWDERS
- BLASTING OPERATION
- SMOKE & FUMES FROM LASER/PLASMA CUTTING

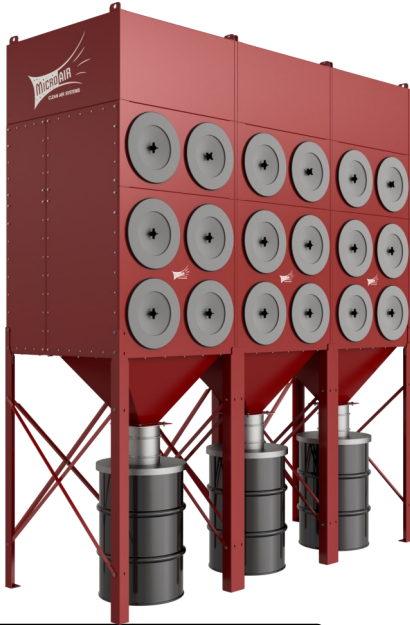

STANDARD FEATURES:

- REVOLUTIONARY ROTO-PULSE® FILTER CLEANING SYSTEMS
- TOP MOUNT OR REMOTE MOUNT FANS
- LARGE CAPACITY DUST DRAWER OR HOPPER
- MOTOR STARTER/OVERLOAD PROTECTION STANDARD CONTROL PACKAGE
- AFTER PULSE CLEANING CYCLE STANDARD
- HEAVY DUTY CONSTRUCTION
- FULL RANGE OF OPTIONS
- RATED FOR INDOOR AND/OR OUTDOOR INSTALLATION
- BEST INDUSTRY WARRANTY

OPTIONS:

- HOPPER SETUP WITH LONG LEGS AND BARREL LID KIT.
- LOW PROFILE UNIT WITH DUST DRAWERS.
- INLET PLENUM
- SILENCER.
- HEPA AFTERFILTER.
- VARIETY OF CARTRIDGE FILTER OPTIONS.
- TOP MOUNT / REMOTE MOUNT FANS SIZED FOR SPECIFIC APPLICATIONS
- MAGNAHELIC OR PHOTOHELIC GAUGES.
- DROP-OUT MODULES FOR HEAVY PARTICULATE
- INTELLI-TOUCH ENERGY SAVING CONTROLS
- EXPLOSION VENTS, BACKBLAST DAMPERS, OSHA/NFPA COMBUSTIBLE DUST COMPLIANCE PACKAGE
- SPARK ARRESTORS

HOW IT WORKS:

Contaminated air is pulled into the inlet plenum at the top of the RP6-3 Cabinet, then travels down through the cartridge

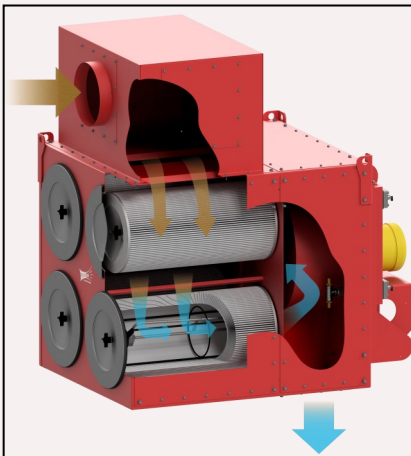

filter sections, where the contaminant is filtered and dropped into the hopper or dust drawer. Breathe Easy, clean safe air is exhausted out the bottom of the unit. Cartridge cleaning is accomplished with Micro Air's proprietary Roto-Pulse® cleaning system, where air is pulsed

into a specially designed stainless steel, rotating tube, engineered with pre-drilled holes. As the air enters this tube, the force of the pulse causes the tube to rotate incrementally inside the cartridge. While rotating, air exits the pre-drilled holes, resulting in air dispersement over

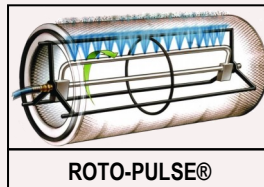

RP6-3 with Safety Filter Modules on Lead Dust Application

the entire surface of the cartridge, providing for an improved cartridge cleaning cycle, compared to competitive backflush cleaning systems .

L3002-RP6-3-05/22



RP6-3

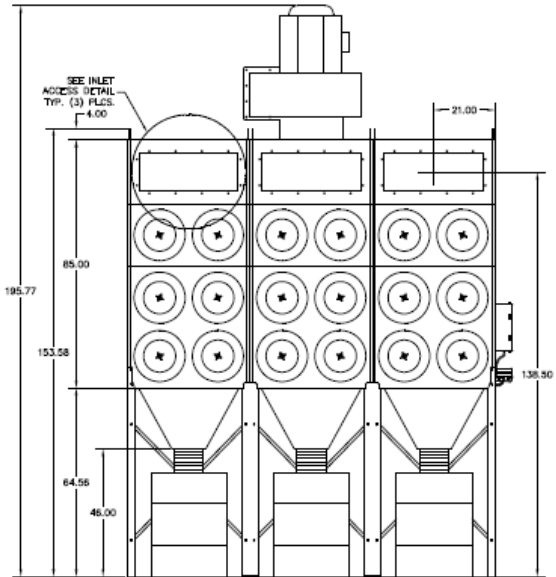
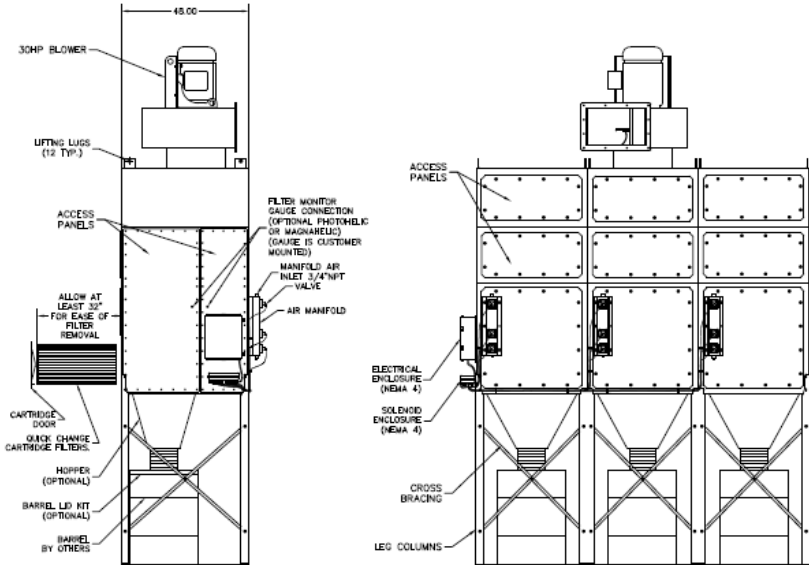
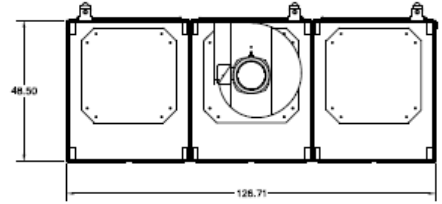
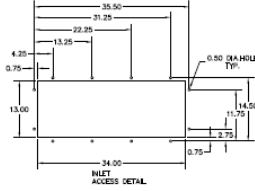

RP6-3 TOP MOUNT FAN—LONG LEGS / HOPPER

RP6-3 SPECIFICATIONS:

OVERALL DIMENSIONS:

158" H X 126" W X 48" D WITH LONG LEGS/HOPPER & INLET PLENUM
 106" H X 126" W X 48" D WITH SHORT LEGS/DUST TRAY & INLET PLENUM

WEIGHT:

*3,350 LBS APPROXIMATE
 *3,650 LBS SHIPPING WEIGHT (APROX)
 *WEIGHT VARIES DEPENDING ON OPTIONS SELECTED

CABINET:

HEAVY DUTY 14 GAUGE GALVANEAL STEEL WITH EXTERIOR SURFACES GROUND SMOOTH

FINISH:

INDUSTRIAL GRADE CRIMSON RED, TEXTURED BAKED ENAMEL PAINT IN SIDE AND OUT. OPTIONAL EPOXY COAT INSIDE & OUT AVAILABLE

FILTER ACCESS:

EASY FRONT ACCESS THROUGH FILTER CAPS

FAN—MOTOR/BLOWER OPTIONS:

VARIOUS SIZES AVAILABLE IN TOP MOUNT OR REMOTE MOUNT CONFIGURATION, SIZED PER APPLICATION SPECIFICATIONS (10,15, 20, OR 30 HP TOP MOUNT / REMOTE MOUNT FANS AVAILABLE AS STD. OPTION) PREMIUM EFFICIENCY "E", TEFC MOTOR/DIRECT DRIVE BLOWER OTHER CUSTOM OPTIONS AVAILABLE

AIR VOLUME:

TYPICALLY 5,000—30,000 CFM
 BASED ON SPECIFIC APPLICATION REQUIREMENTS

FILTER CHANGE INDICATOR:

MAGNEHELIC GAUGE OR PHOTOHELIC GAUGE

FILTRATION:

EIGHTEEN EA. HIGH EFFICIENCY, 80/20 BLEND, FIRE-RETARDANT CARTRIDGE FILTERS, 250 SF MEDIA PER FILTER, 4,500 SF TOTAL MEDIA
 *MULTIPLE CARTRIDGE MEDIA OPTIONS AVAILABLE

CONTROLS:

SOLID STATE TIMER BOARD, FACTORY WIRED AND INSTALLED—FULL CONTROL PACKAGE AVAILABLE AS AN OPTION
 INTELLI-TOUCH ENERGY SAVINGS CONTROLS—OPTION

INLET / EXHAUST:

INLET PLENUM FOR TOP MOUNT OR REMOTE MOUNT FANS
 EXHAUST - OUT BOTTOM OF UNIT

MAX CURRENT

10 HP, 230/460V—24.6 / 12.3 AMP
 15 HP, 230/460V—35.0 / 17.5 AMP
 20 HP, 230/460V—47.0 / 23.5 AMP
 30 HP, 230/160V— 69.0 / 34.5 AMP

NOISE LEVELS:

DEPENDENT UPON OPTIONS SELECTED—CONSULT FACTORY

WIND LOAD RATING:

100 MPH

CABINET PRESSURE RATING:

+/- 20 INCHES WC

COLLECTION OPTIONS:

3 EA. HOPPERS WITH 10" DIA COLLAR OR 3 EA. DUST TRAYS

COMPRESSED AIR:

REQUIRES 80—90 PSI CLEAN, DRY AIR & MINIMUM 3/4" AIR LINE

CARTRIDGE CLEANING SYSTEM:

ROTO-PULSE® INCREMENTAL ROTATING TUBE WITH PRE-DRILLED HOLES. AS AIR IS PULSED INTO THE TUBE, IT ROTATES AND AIR EXITS THE PRE-DRILLED HOLES, PROVIDING A HIGHLY EFFICIENT AND TOTAL CLEANING OF THE CARTRIDGE FILTER

OFF-LINE CARTRIDGE CLEANING:

STANDARD EQUIPMENT DESIGNED TO CLEAN FILTERS AFTER UNIT IS TURNED OFF FOR OPTIMAL OFF-LINE CARTRIDGE CLEANING. TIMER CAN BE ADJUSTED BETWEEN 0 AND 17 MINUTES

SPECIFICATIONS SUBJECT TO CHANGE WITHOUT NOTICE