



BREATHE EASY...Solutons for Clean Safe Air

EXTREME AIR DOWNDRAFT TABLE XA46MAX

Specifications and Technical Data

TYPICAL APPLICATIONS

- Grinding Dust
- Sanding / Polishing Dust
- Welding Smoke & Fumes
- Mixing and / or Filling Operations
- Deburring
- Soldering



STANDARD FEATURES:

- 250 FPM Velocities—6,000 CFM
- Baffle Spark Arrestance
- Fire Retardant Cartridge Filter
- Roto-Pulse® Filter Cleaning System
- Ergonomic Front Overhang
- Hinged Filter Door with Easy Open Latches for Quick Filter Change-Out
- Factory Pre-Wired Electrics
- Easy Open, High Capacity Dust Tray
- Perforated Metal Work Surface
- 0-5" MiniHelic Filter Gauge

OPTIONS:

- Back and Side Shields w/Hinged Wing Walls
- Soft-Touch Mat on Perforated Metal Work Surface
- Industrial Casters / Levelling Legs
- Multiple Application Specific Media Options
- Dust Proof 48" LED Light Fixture
- Manual Pulse or Auto-Pulse Cartridge Cleaning System
- Silencer

HOW IT WORKS:

Roto-Pulse® Cartridge cleaning system provides for 30-40% better cleaning of the cartridges. Air is pulsed into a specially designed aluminum rotating tube equipped with pre-drilled holes. As the air enters this tube, the force of the pulse causes the tube to rotate. As the tube spins, air exits the pre-drilled holes resulting in air hitting the entire inside length of the cartridge, pulsing dirt particles away from the filter for a much more efficient cleaning cycle and increased filter life.

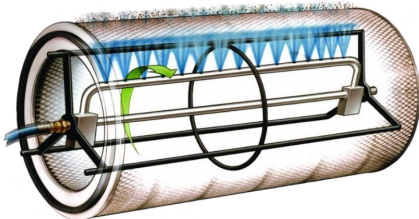

ENGINEERED SAFETY

Built-In Baffle Spark Arrestance provides ultimate protection from sparks reaching the filter media, offers ease of maintenance and provides for increased load capacities.



L2981-03/2018



XA46M Downdraft Table

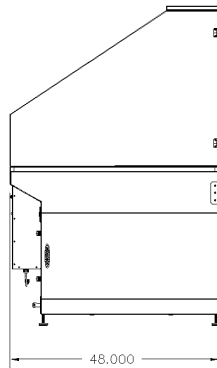
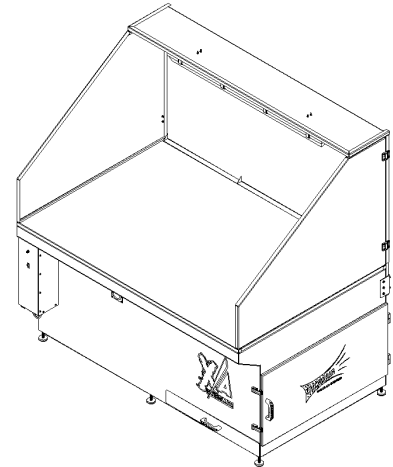
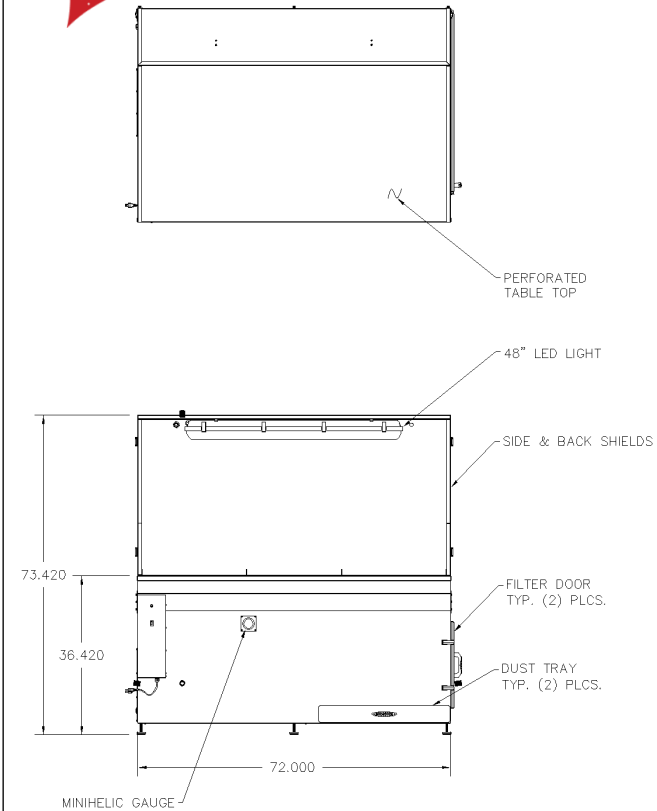

XA46M SPECIFICATIONS:

OVERALL DIMENSIONS:

49" D X 75"W X 36" H—NO BACKSHIELD
 49" D X 75" W X 73" H—WITH BACKSHIELD

TABLE TOP DIMENSIONS:

48" D X 72" W

WEIGHT:

1,275 LBS, ACTUAL VARIES DEPENDING ON
 OPTIONS SELECTED

CABINET:

14 GA. WELDED GALVANEAL STEEL W/EXTERIOR
 SURFACES GROUND SMOOTH

FINISH:

INDUSTRIAL GRADE TEXTURED BAKED
 CRIMSON RED ENAMEL PAINT—INSIDE AND OUT

FILTRATION:

TWO EA. FIRE-RETARDANT CARTRIDGE,
 300-500 SF MEDIA—DEPENDENT ON MEDIA
 SELECTED—MERV 11—16 AVAILABLE

ROTO-PULSE® CLEANING SYSTEM:

REVOLUTIONARY CLEANING SYSTEM, THAT
 CLEANS THE ENTIRE SURFACE OF CARTRIDGE,
 FOR CLEANER FILTERS & EXTENDED FILTER
 LIFE

FILTER ACCESS:

SIDE LOAD THROUGH HINGED DOOR FOR
 EASE OF ACCESS

EXHAUST:

STRAIGHT THROUGH / UPBLAST WITH SILENCER
 TRANSITION

MOTOR:

5 HP, 230 / 460V, 3 PHASE, TEFC

MAX CURRENT:

12.6 / 6.3 AMPS

BLOWER:

BELT DRIVEN, FORWARD INCLINED BLOWER

AIR FLOW:

250 FPM ACROSS TABLE-TOP— 6,000 CFM

FILTER CHANGE INDICATOR:

0-5" MINIHELIC GAUGE

ELECTRICAL:

230 /460V, 3 PHASE— INCLUDES
 FACTORY WIRED ON/OFF SWITCH, LIGHT
 SWITCH, & PULSE PUSH BUTTON

LOAD CAPACITY:

1,800 LBS

NOISE LEVEL:

79 dBA AT OPERATOR
 74 dBA AT OPERATOR WITH SILENCER / HEPA

CONTROLS:

ON/OFF SWITCH WITH STARTER AND
 OVERLOAD RELAY