

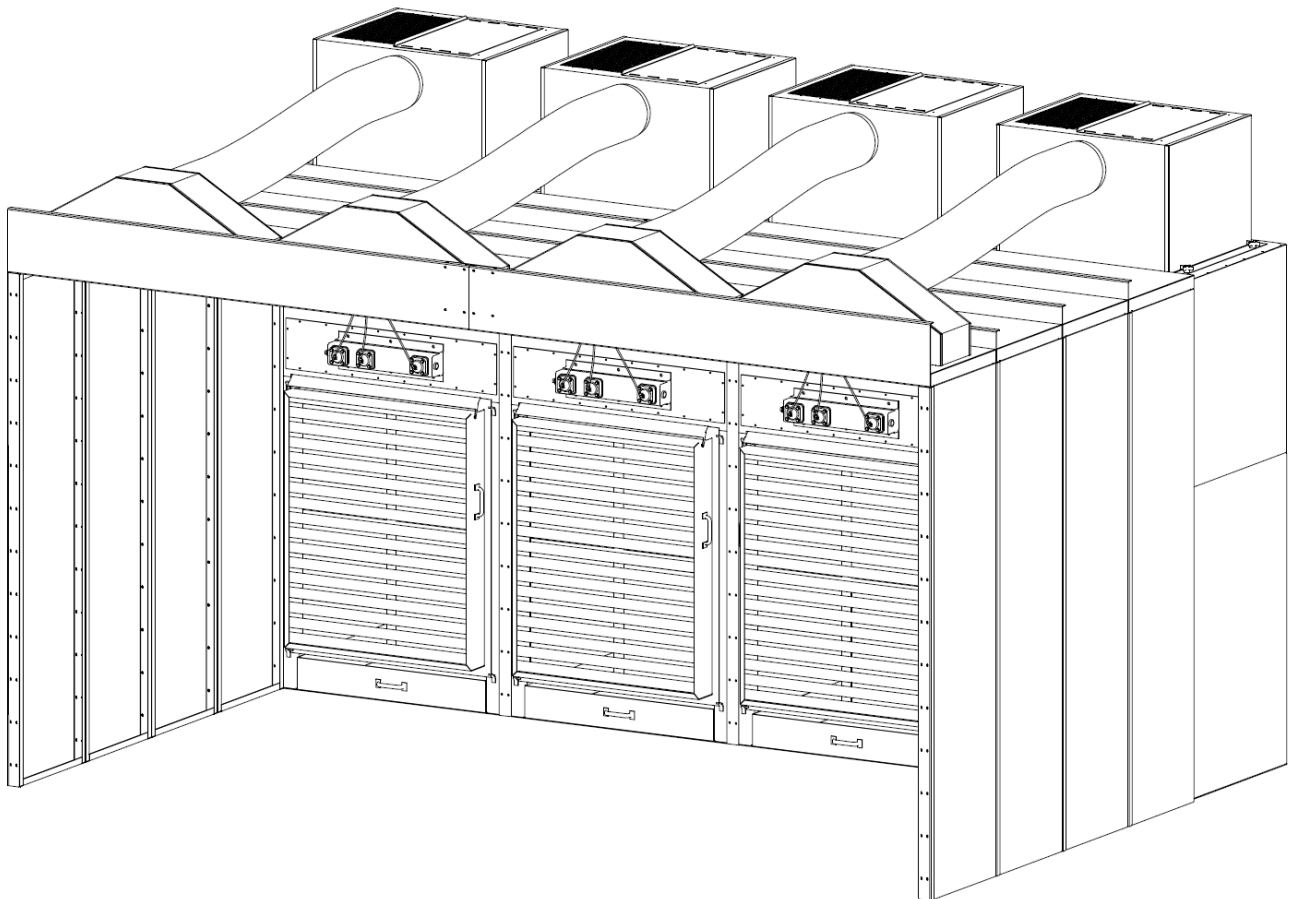

CLEAN AIR BOOTH

INSTALLATION MANUAL



This manual contains specific cautionary statements relative to worker safety. Read this manual thoroughly and follow as directed. It is impossible to list all of the hazards of dust control equipment. It is important that use of the equipment be discussed with a Micro-Air Representative. Persons involved with the equipment or systems should be instructed to operate in a safe manner.

MICRO AIR INC.
www.microaironline.com

CONTENTS

TABLE 1 – 8’ W Booths

COMPONENT DESCRIPTION	CABIR1-888	CABIN1-888	CABUR1-888	CABUN1-888	CABIR2-888	CABIN2-888	CABUR2-888	CABUN2-888
INSULATED	YES	YES	NO	NO	YES	YES	NO	NO
REGAIN	YES	NO	YES	NO	YES	NO	YES	NO
SIDE PANEL	8	8	8	8	8	8	8	8
BACK PANEL	2	2	2	2	0	0	0	0
TOP PANEL	3	4	3	4	3	4	3	4
REGAIN TOP PANEL	1	0	1	0	1	0	1	0
VERTICAL SUPPORT	8	8	8	8	8	8	8	8
HEADER	1	1	1	1	1	1	1	1
HEADER BRACE	0	0	0	0	0	0	0	0
HORIZONTAL SUPPORT	3	3	3	3	3	3	3	3
HORIZONTAL SUPPORT BRACE	0	0	0	0	0	0	0	0
10" WYE	1	0	1	0	0	0	0	0
CABINET CONNECTION PLATE	2	2	2	2	0	0	0	0
#8-18x3/4" SLF DRILLING/TAPPING	32	0	32	0	32	0	32	0
1/4"-20x3/4" BOLT	252	252	252	252	204	204	204	204
1/4"-20 NUT	222	222	222	222	168	168	168	168
1/4" FLAT WASHER	474	474	474	474	372	372	372	372
1/4" LOCK WASHER	474	474	474	474	372	372	372	372

TABLE 2 – 12’ W & 16’ W Booths

COMPONENT DESCRIPTION	CABIR3-1288	CABIN3-1288	CABUR3-1288	CABUN3-1288	CABIR4-1688	CABIN4-1688	CABUR4-1688	CABUN4-1688
INSULATED	YES	YES	NO	NO	YES	YES	NO	NO
REGAIN	YES	NO	YES	NO	YES	NO	YES	NO
SIDE PANEL	8	8	8	8	8	8	8	8
BACK PANEL	0	0	0	0	0	0	0	0
TOP PANEL	6	8	6	8	6	8	6	8
REGAIN TOP PANEL	3	0	3	0	2	0	2	0
VERTICAL SUPPORT	8	8	8	8	8	8	8	8
HEADER	2	2	2	2	2	2	2	2
HEADER BRACE	1	1	1	1	1	1	1	1
HORIZONTAL SUPPORT	6	6	6	6	6	6	6	6
HORIZONTAL SUPPORT BRACE	3	3	3	3	3	3	3	3
10" WYE	0	0	0	0	0	0	0	0
CABINET CONNECTION PLATE	0	0	0	0	0	0	0	0
#8-18x3/4" SLF DRILLING/TAPPING	48	0	48	0	64	0	64	0
1/4"-20x3/4" BOLT	297	294	297	294	324	324	324	324
1/4"-20 NUT	255	252	255	252	276	276	276	276
1/4" FLAT WASHER	552	546	552	546	600	600	600	600
1/4" LOCK WASHER	552	546	552	546	600	600	600	600

NOTE: Refer to pages 13-16 for assembled drawings of each booth.

Note: Before assembly, remove parts from packaging and inspect for any possible damage incurred during shipping. Identify each part and verify quantities.

EQUIPMENT REQUIRED

1. Step ladders
2. Overhead Crane/Forklift
3. Lifting Straps
4. 3/8" Wrenches and/or Ratchet with appropriate sockets
5. C-clamp pliers
6. Hammer or mallet
7. Protective/Work gloves

WARNING!!

Proper handling and care must be taken when assembling equipment. Use proper eye wear and gloves. Pieces can be heavy and sharp around edges.

INSTALLATION

1. Assemble side panels to CAB module with the appropriate 1/4" hardware (See **FIG. 1**). Each panel is bolted on in twelve places onto the CAB module. Bolt through holes closest to the inside flange of the side panels. Make sure side panels are flush with CAB module at the bottom. Side panels should stick out 1.25" from CAB side wall. Bolt down side panels to ground using at least 2 anchors per panel (see **FIG. 2**). Anchors are NOT provided.

NOTE: For booths with a single CAB module, install back panels to CAB module first. Stand back panels next to CAB module. Use cabinet connection plate to install the back panels to the CAB module (see **FIG. 3**). Once the back panels are installed, bolt side panels to the back panels.

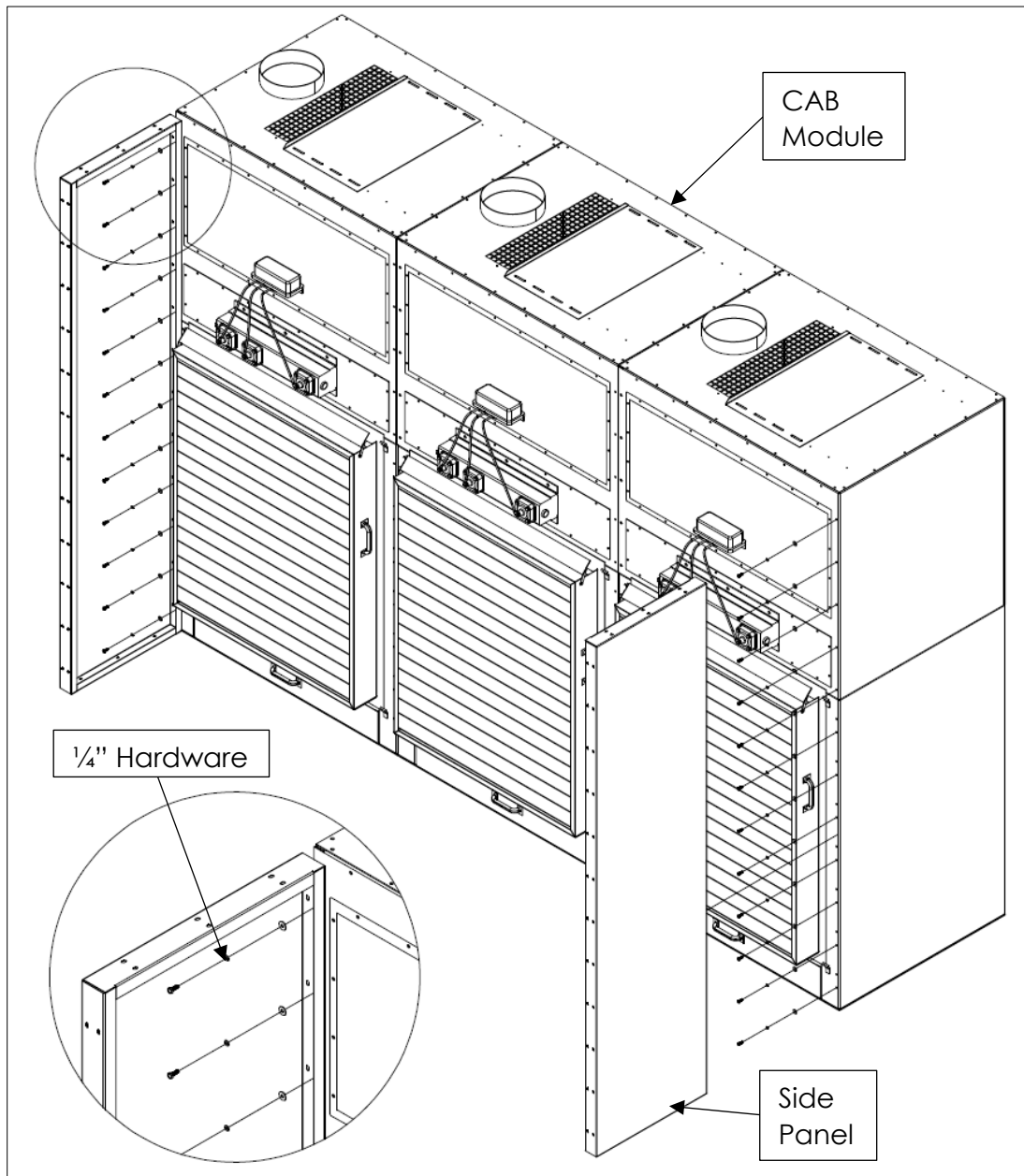
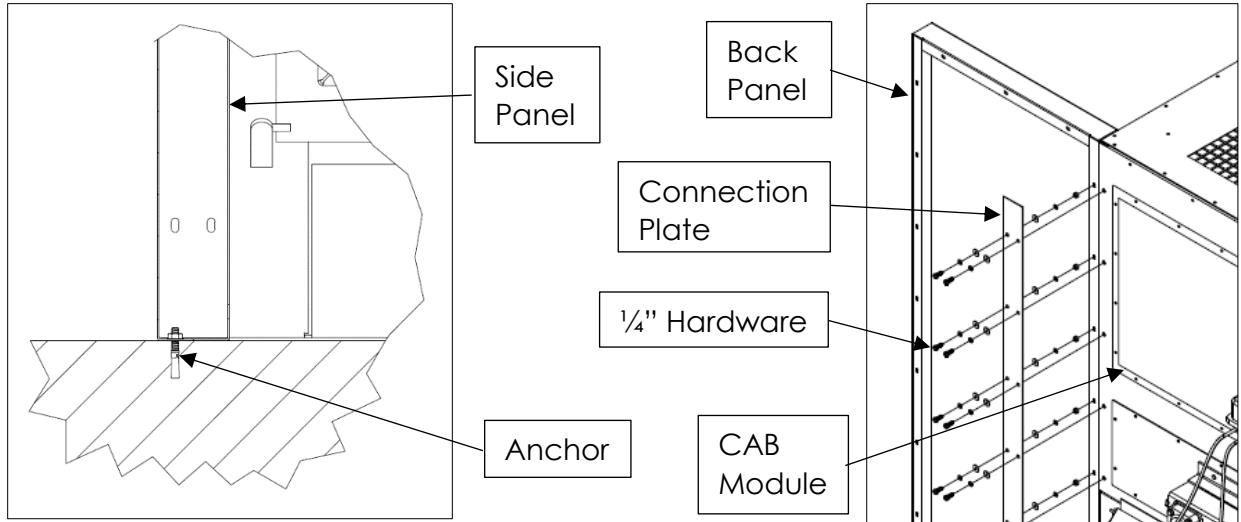

FIG. 1



- Assemble top panels together (Skip this step for 8' W booths). The top panel assemblies consist of two panels. The outside edge of the panel is 5.25" to the center of the mounting slot. The inside edge is 4.00" to the center of the mounting slot. The outside edges of the panels do not have any mounting slots (see FIG. 4). The inside ends of each top panel are bolted together in three places. If the top panels are insulated, bolt through the holes' nearest flange (See FIG. 5). Make sure sides of panels lay flush with each other.

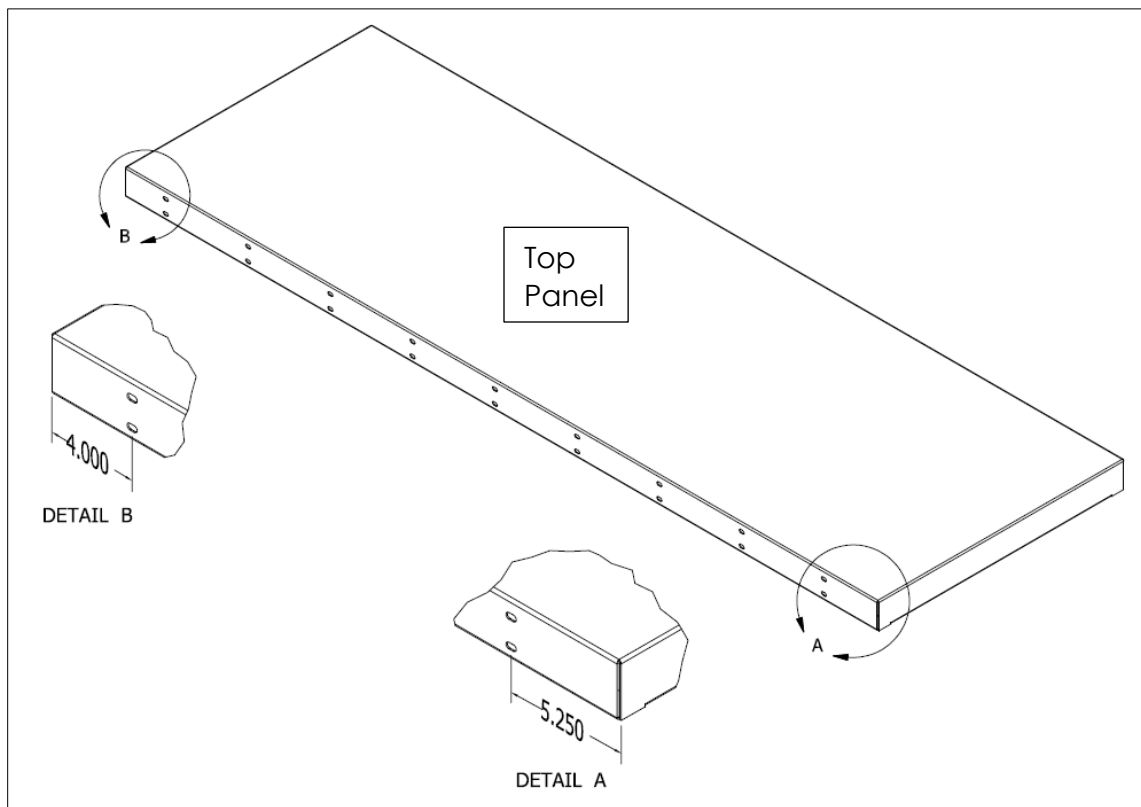

FIG. 4

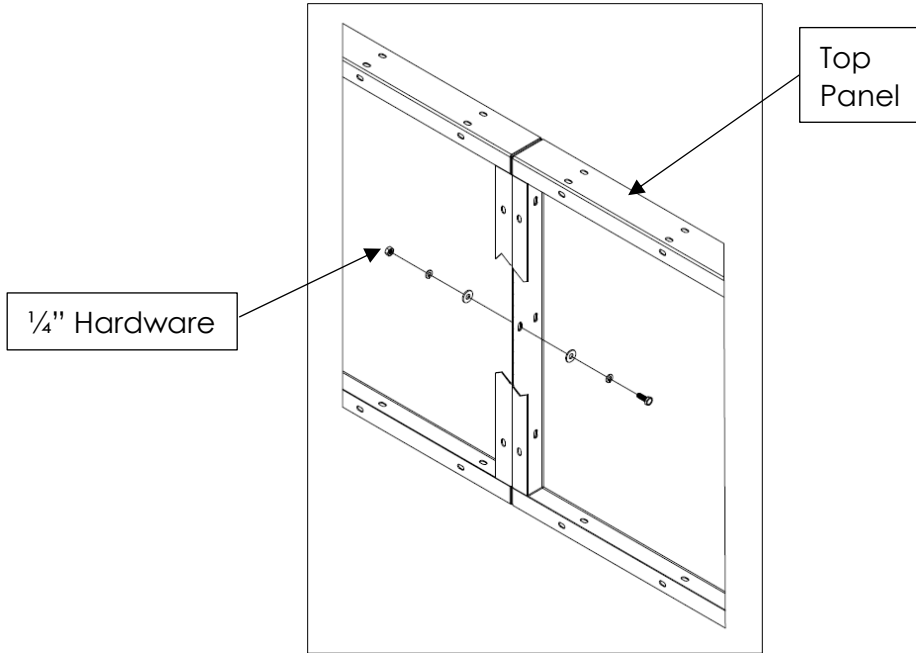

FIG. 5

NOTE: For the 12' W booth with regain, the regain portion of the top panel assembly will consist of 3 top panels bolted together. The outer panels are 48.25" wide each and the mid panel is 50.00" wide. The distance between mounting slots is 8.00" in the middle. The outside panels do not have mounting slots (See FIG. 6).

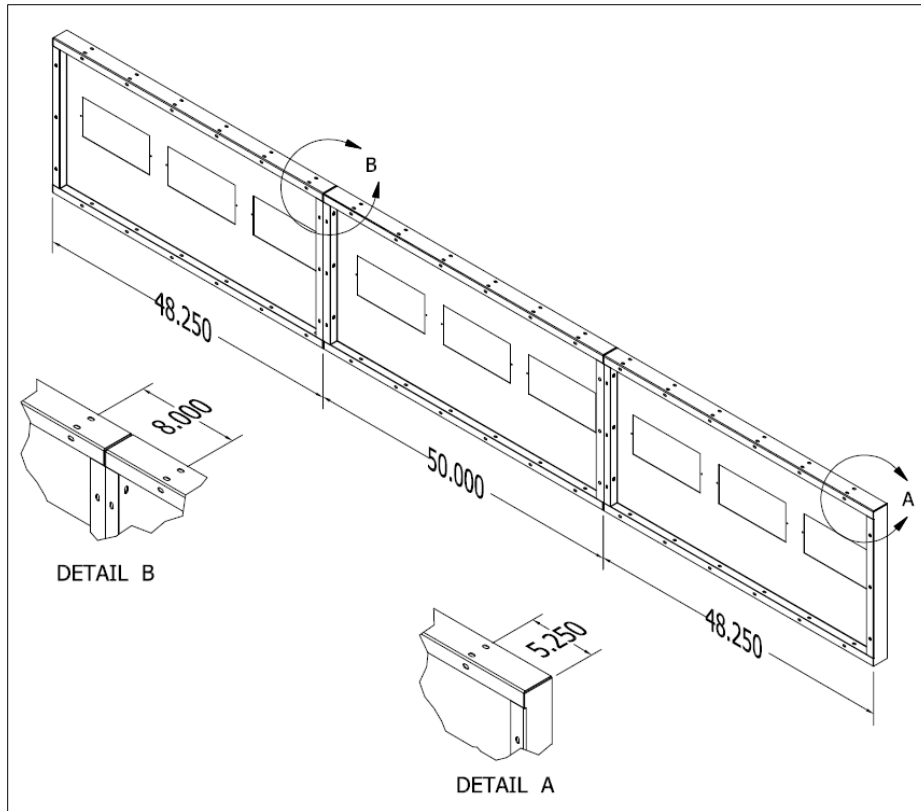

FIG. 6

3. Seat horizontal supports at the front of the top panel segment (Skip this step for 8' W booths). Bolt together the horizontal supports with the horizontal support brace (12 bolts total, see **FIG. 7**).

NOTE: The horizontal support braces will have holes on the top flange. 8' W booths do not include horizontal support braces.

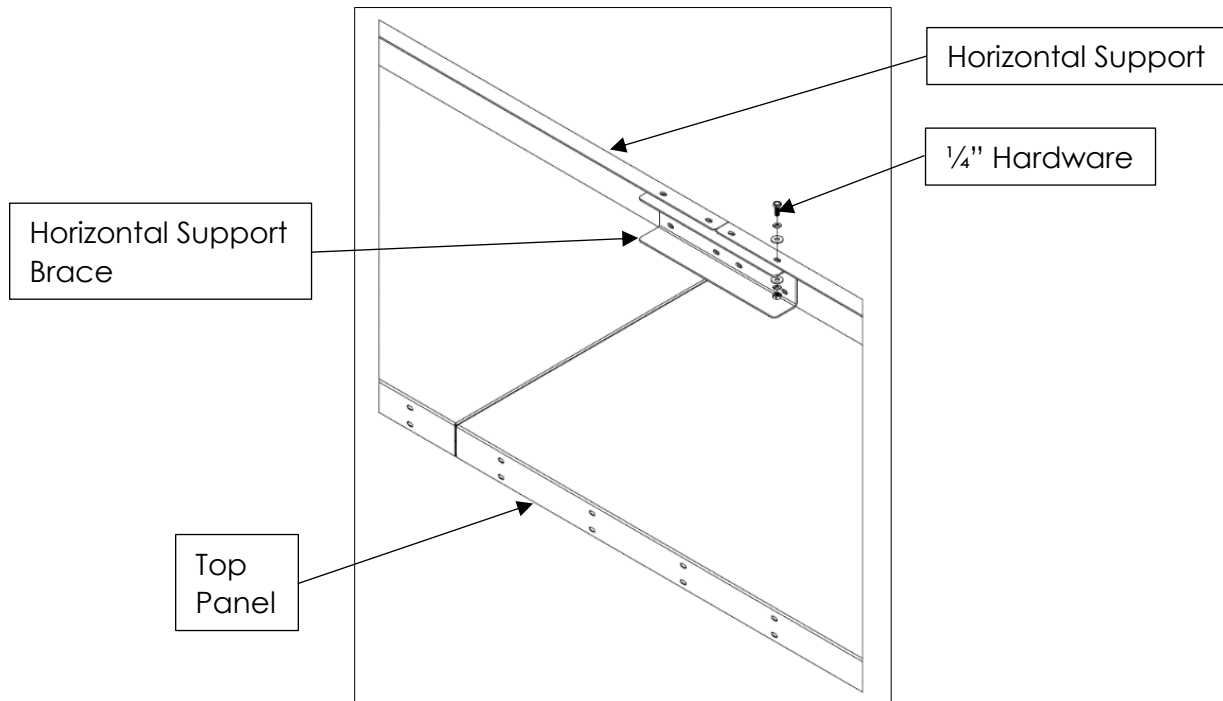

FIG. 7

4. With top panel segment and support braces together, use c-clamp pliers to hold assembly together prior to transfer onto the CAB module and side panels (see **FIG. 8**). If no c-clamps are available it is possible to use bolts and nuts provided to keep the assembly secure but they will need to be removed prior to bolting on the next top panel segments (see **FIG. 9**).

NOTE: For ease of assembly it is suggest to assemble each top panel segment in front of CAB/BOOTH unit.

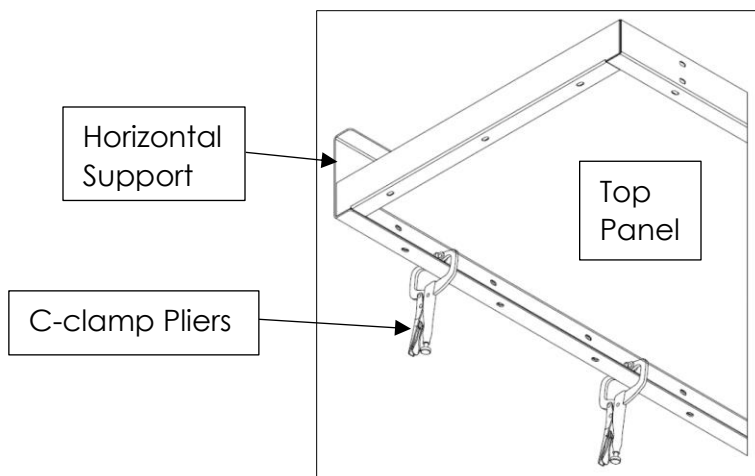
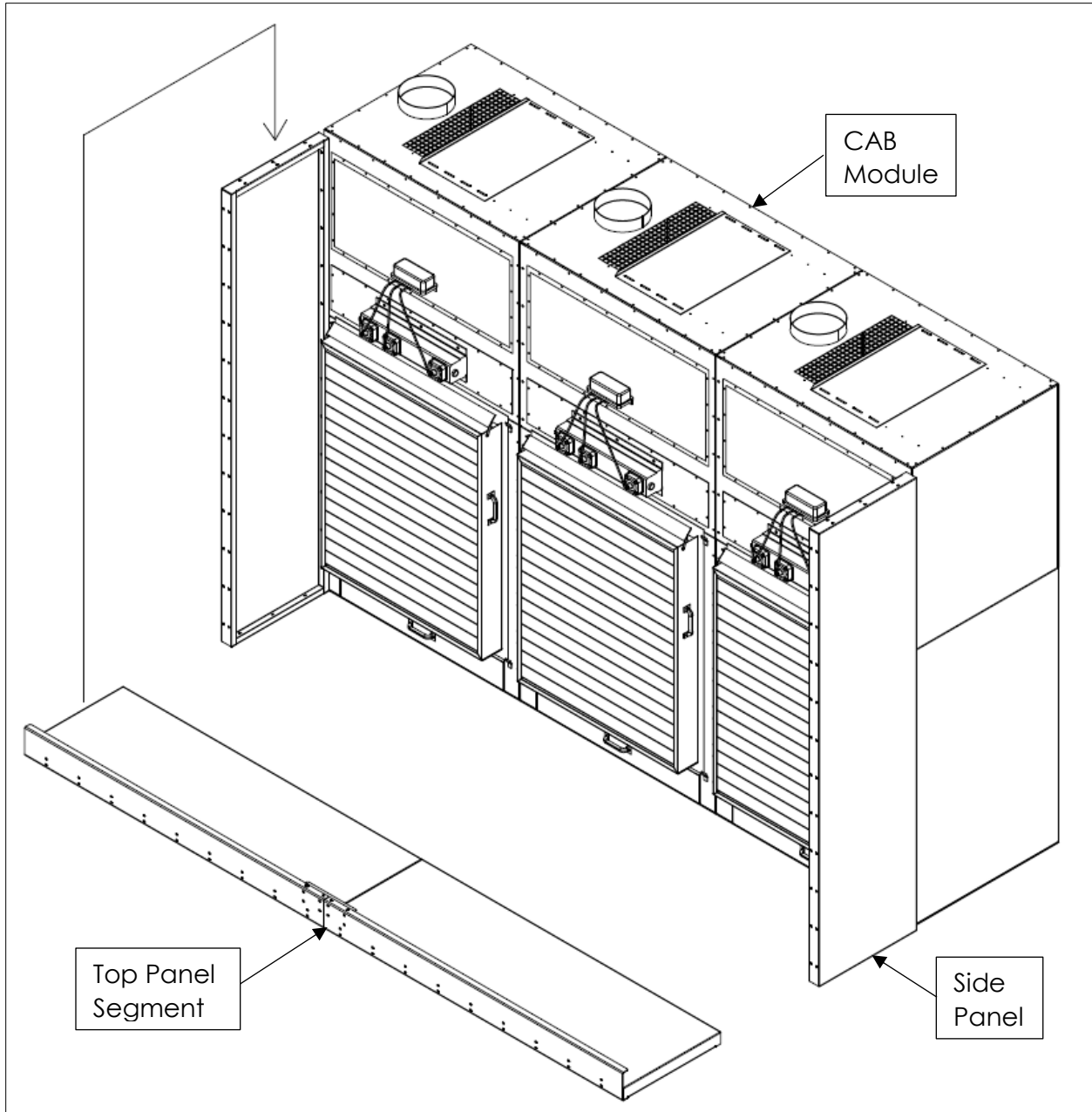

FIG. 8

**FIG. 9**

5. Once the top panel is set flush on the side panels, bolt to the CAB module and panels (see **FIGS. 10, 11**). The top panel assembly will bolt to the CAB module and in the side panels. Make sure to bolt through holes located nearest inside flange of panels.

Note: Do not tighten bolts of the top panel segment until next top panel segment is in place.

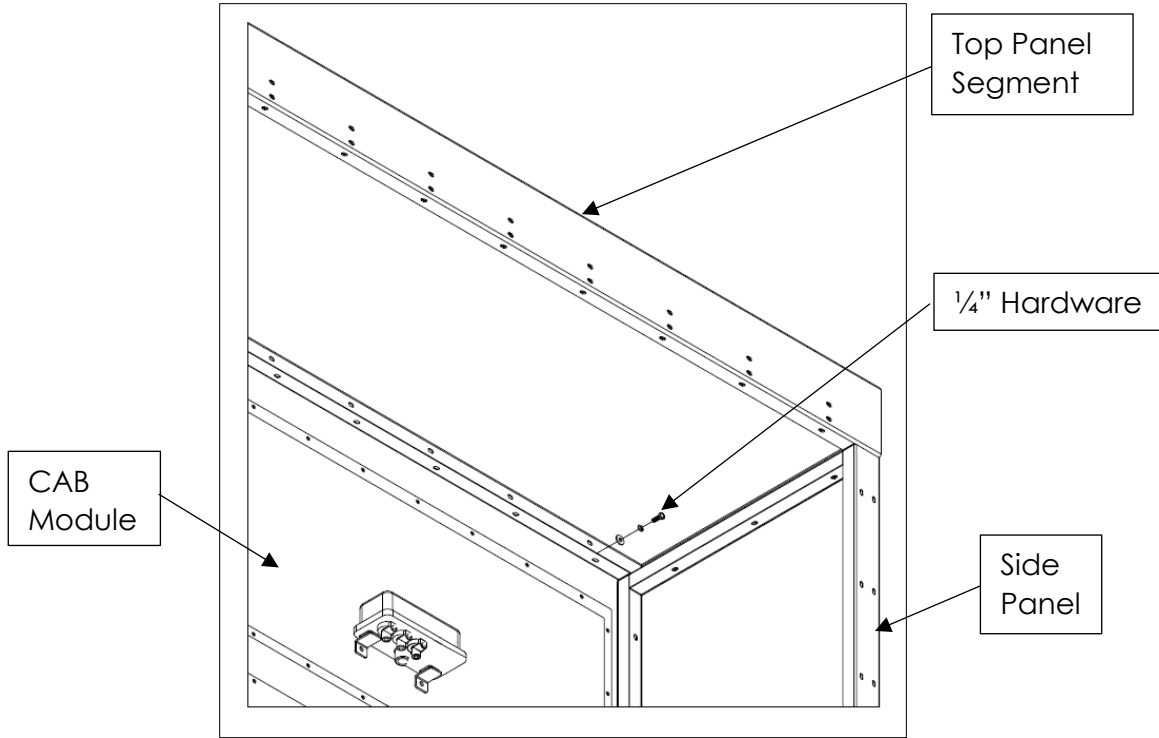

FIG. 10

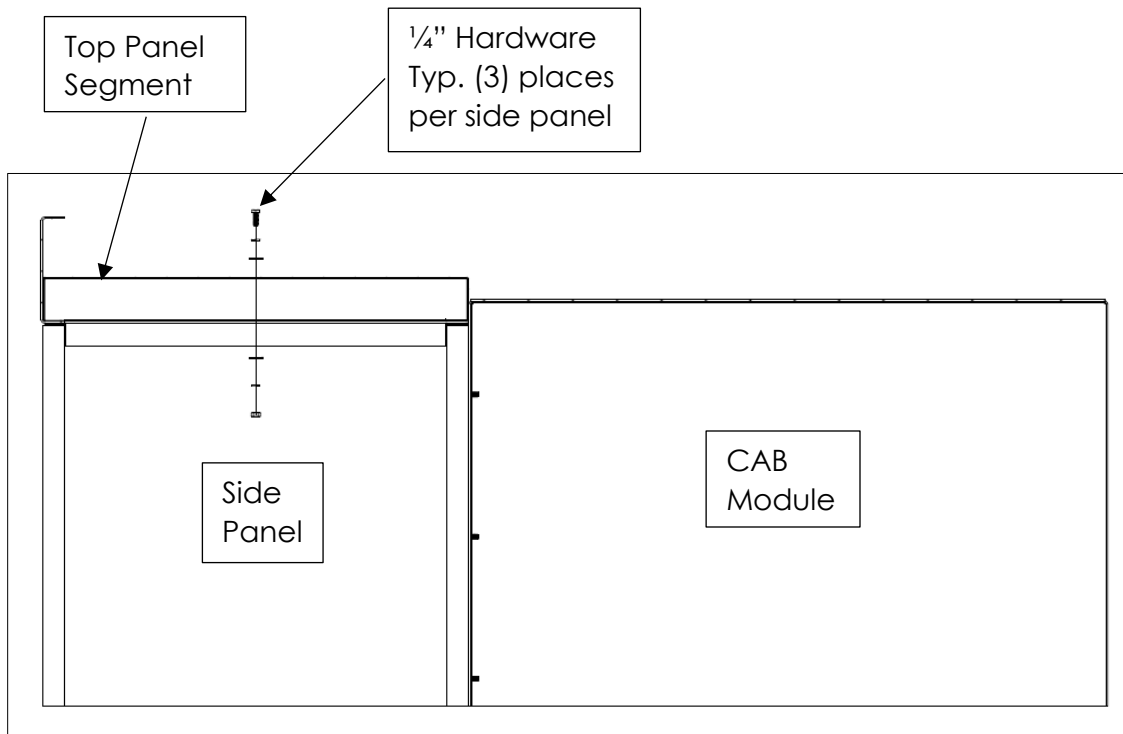

FIG. 11

6. Bolt the next set of side panels to the booth. These side panels are joined with the vertical supports. Make sure the flange on the vertical support sits on the outside of the side panels (see **FIGS. 12, 13**).

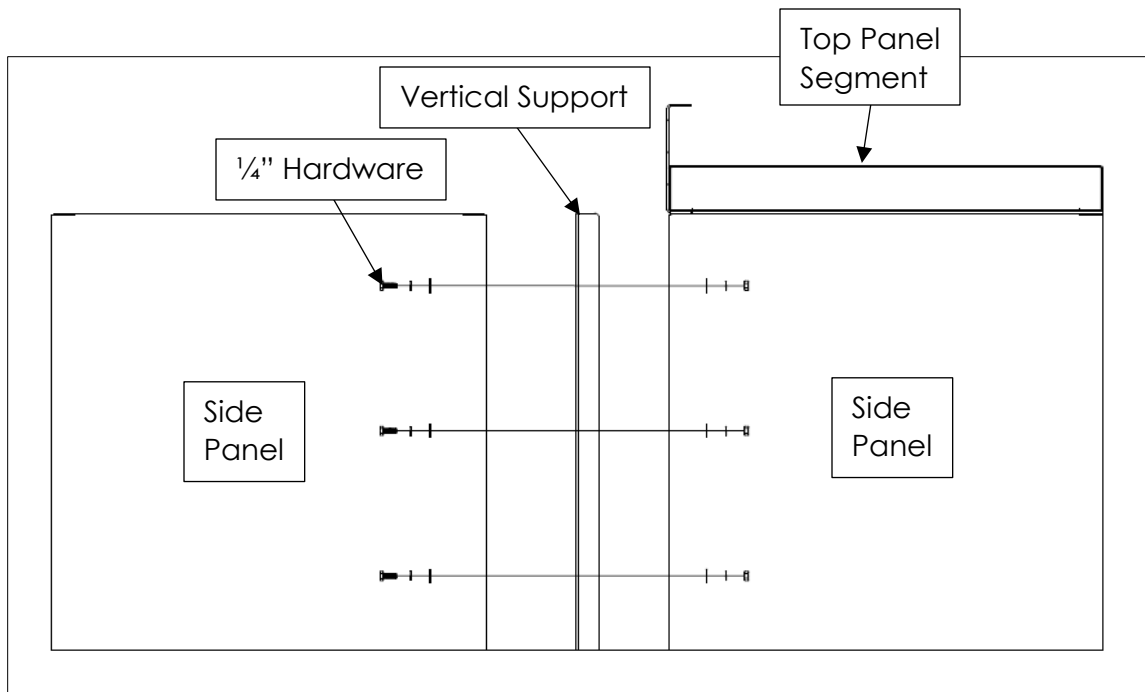

FIG. 12

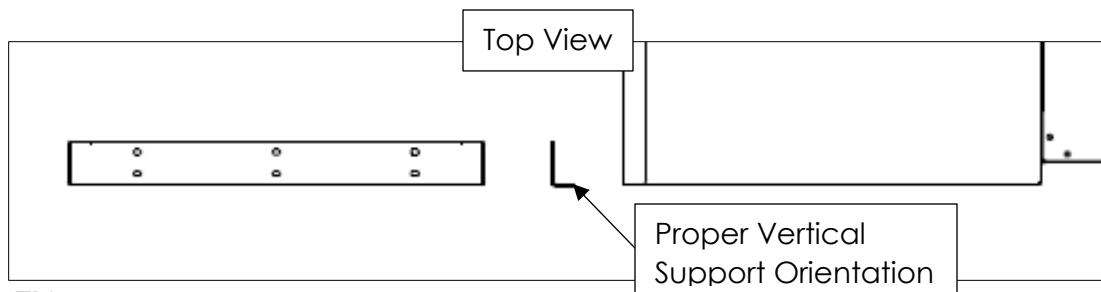

FIG. 13

7. Assemble and install the next top panel segment following steps 2-5. When aligning horizontal supports use hammer or mallet to tap edge into place. Assemble side panels and vertical supports following step 6. Repeat process 2 more times. Tighten down all bolts once all panels and braces have been installed.

NOTE: The last top panel segment that will go on the booth will use two Header beams (8' W booths only utilize one Header beam), and the Header Brace in lieu of the horizontal support and horizontal brace. The header brace is bolted onto both headers with 12 bolts and bolted to the top panels through the bottom side (see **Figs. 14, 15, 16**).

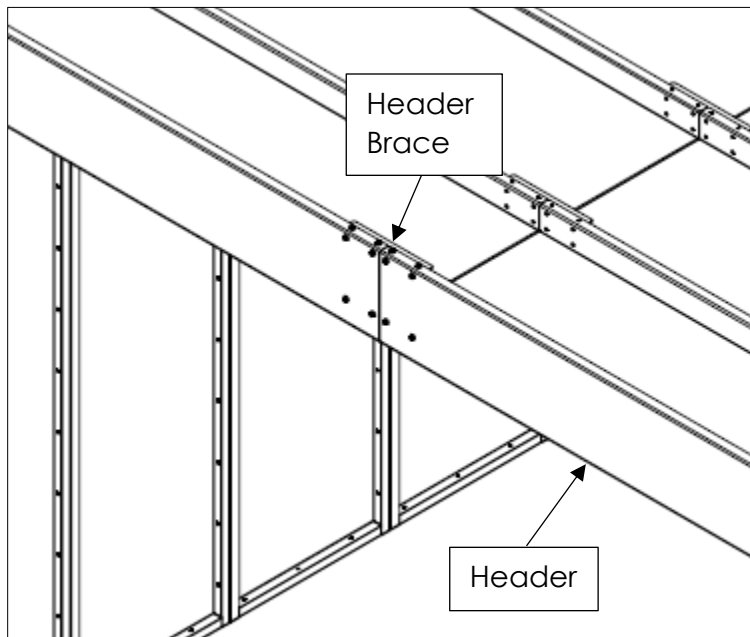

FIG. 14

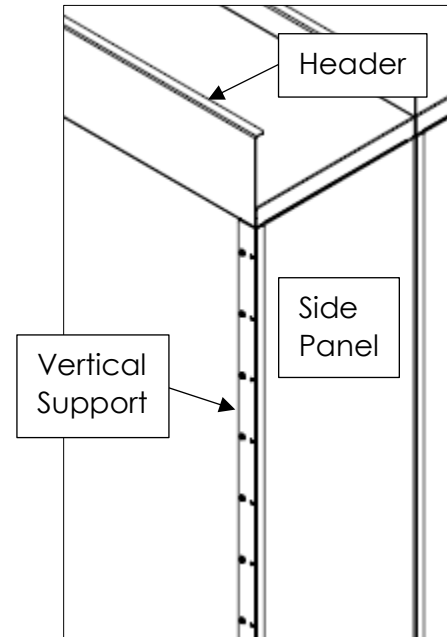

FIG. 15

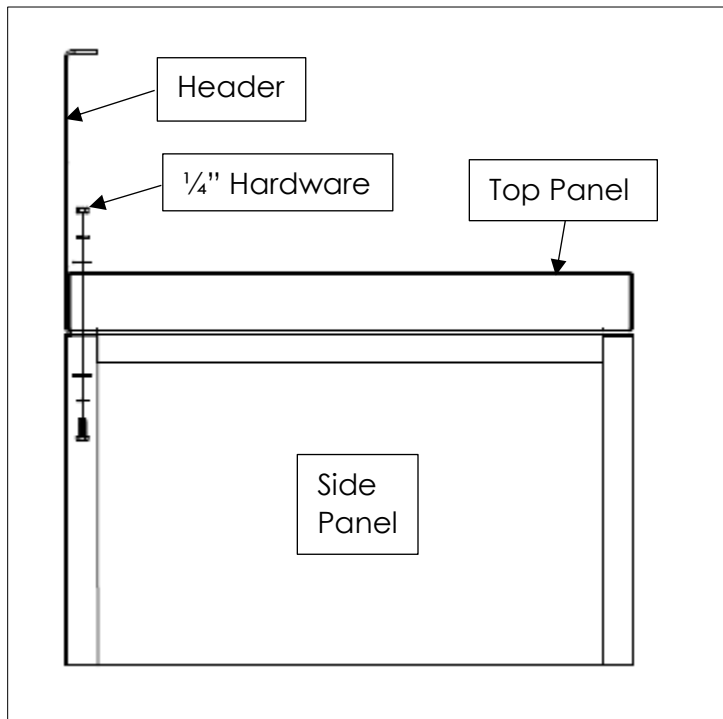

FIG. 16

REGAIN

NOTE: HEPA filtration is recommended for use with ALL Regain applications

1. Remove parts from packaging and inspect for any possible damage incurred during shipping.
2. Set the Regain module on top of the booth.
3. Using the provided self-drilling/self-tapping screws, attach the Regain module to the regain panel (see **FIG. 17**).
4. Mount the grilles on the Regain panel with the provided hardware. The vanes of the grille can be redirected slightly to adjust Regain airflow.
5. Once the regain assembly is installed, connect the 10" hose between the regain adjustment plate can be moved to provide the best return air flow for your particular application.

NOTE: It is recommended to install the Regain assembly through the collar opening on the assembly. For insulated booths, the Regain grilles will be installed on the panels. For un-insulated booths, use hardware provided in register package to install to top panel.

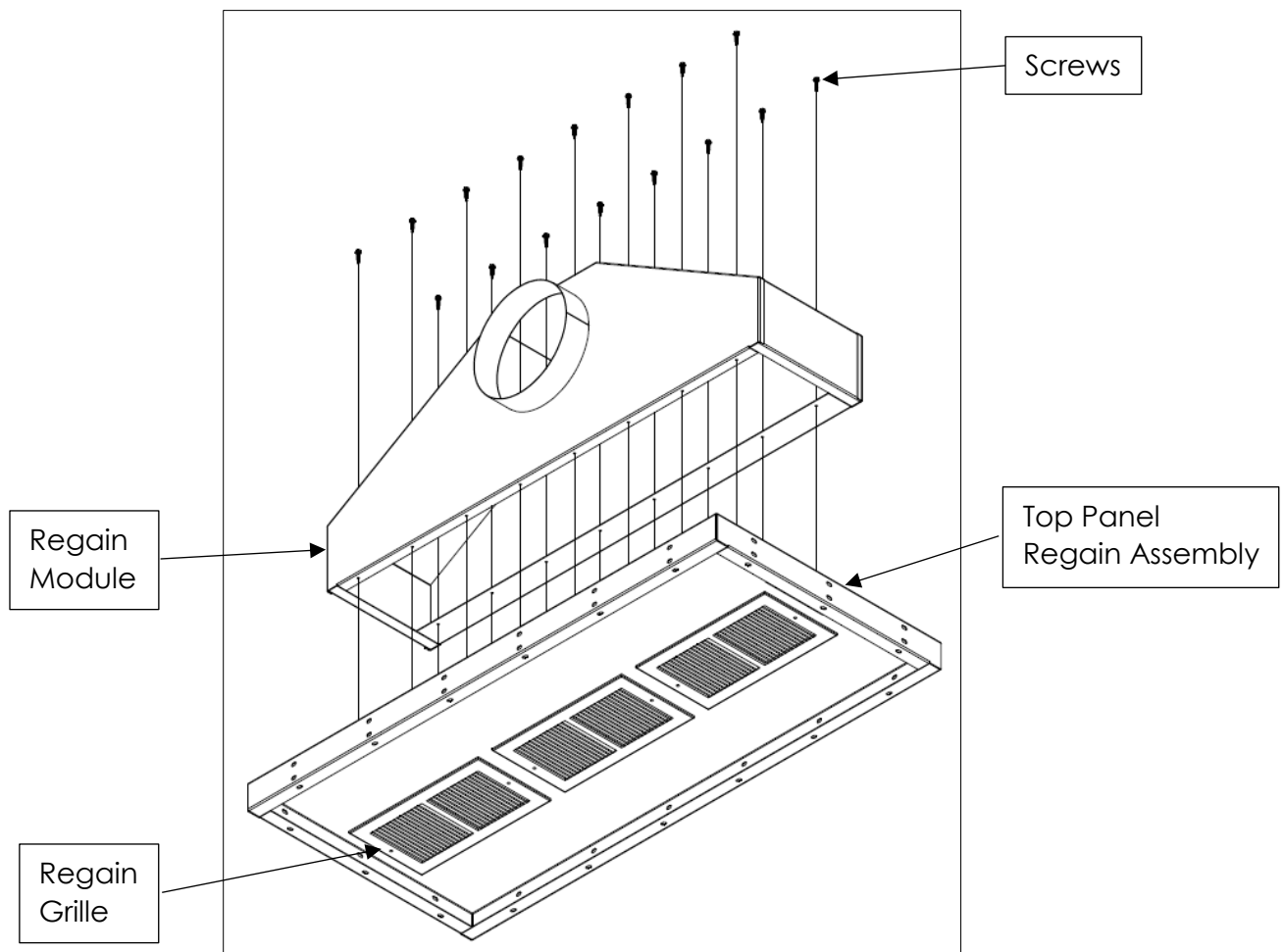
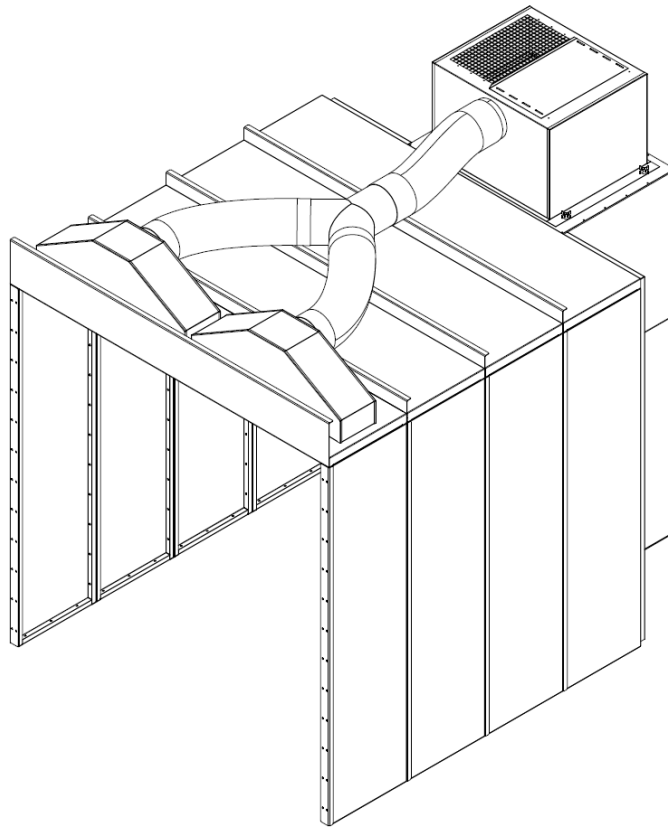
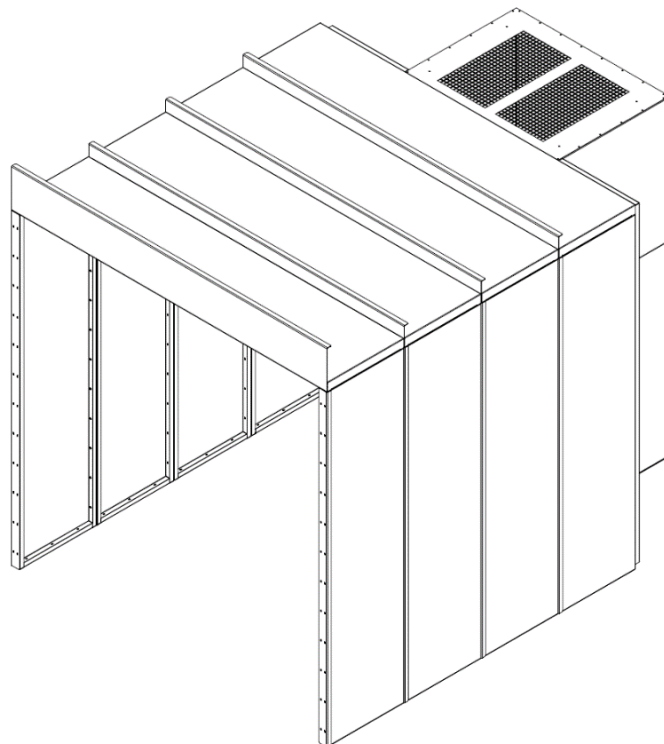

FIG. 17

CABIR1-888 & CABUR1-888



CABIN1-888 & CABUN1-888



CABIR2-888 & CABUR2-888

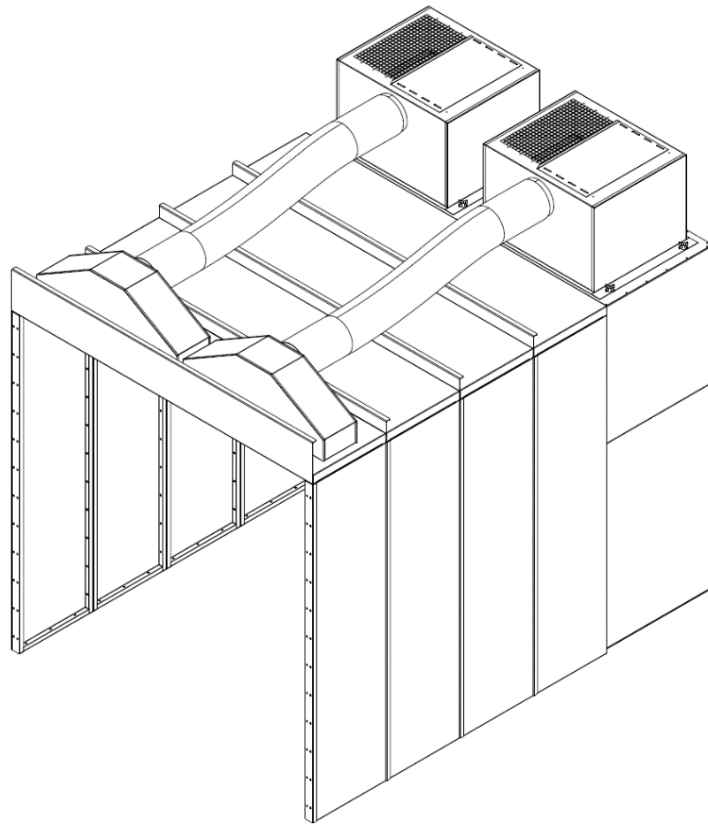

CABIN2-888 & CABUN2-888

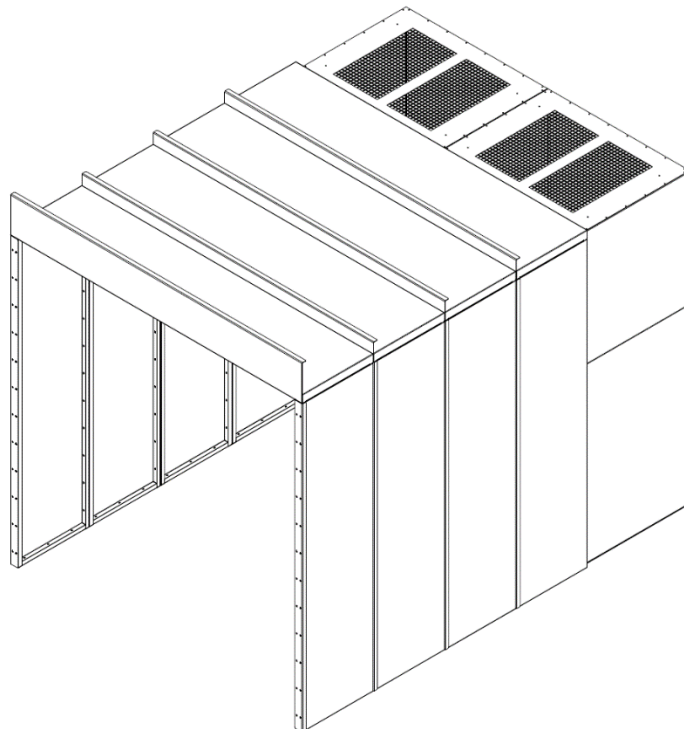

CABIR3-1288 & CABUR3-1288

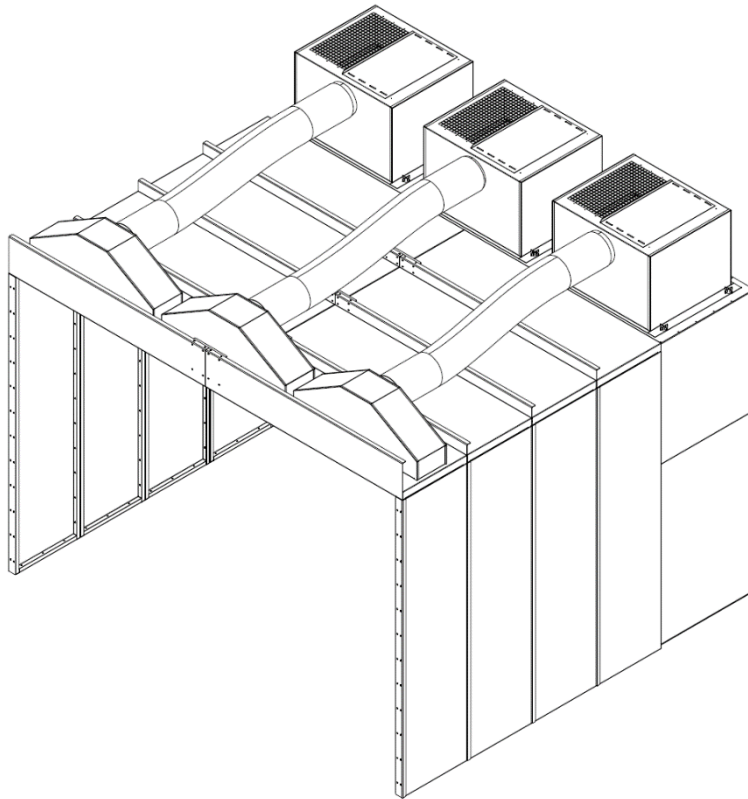

CABIN3-1288 & CABUN3-1288

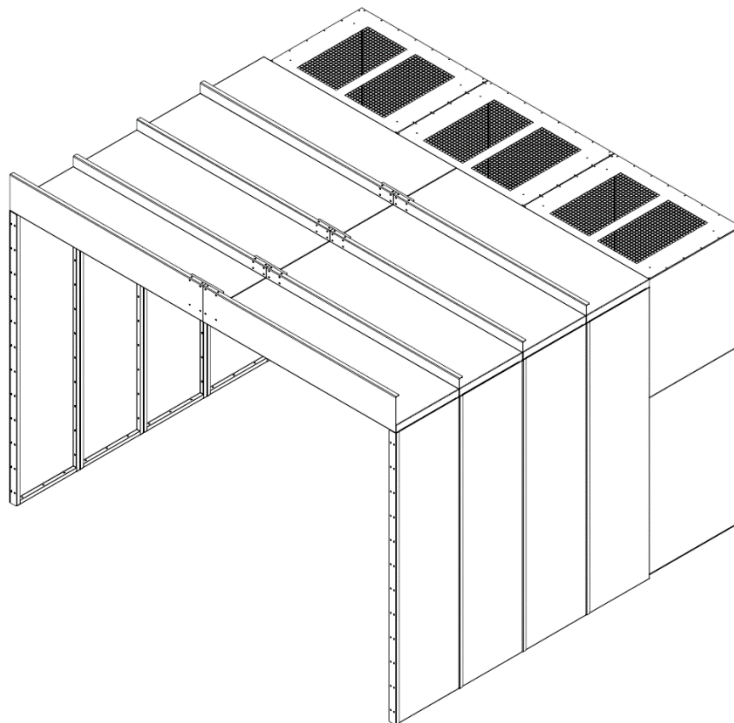

CABIR4-1688 & CABUR4-1688

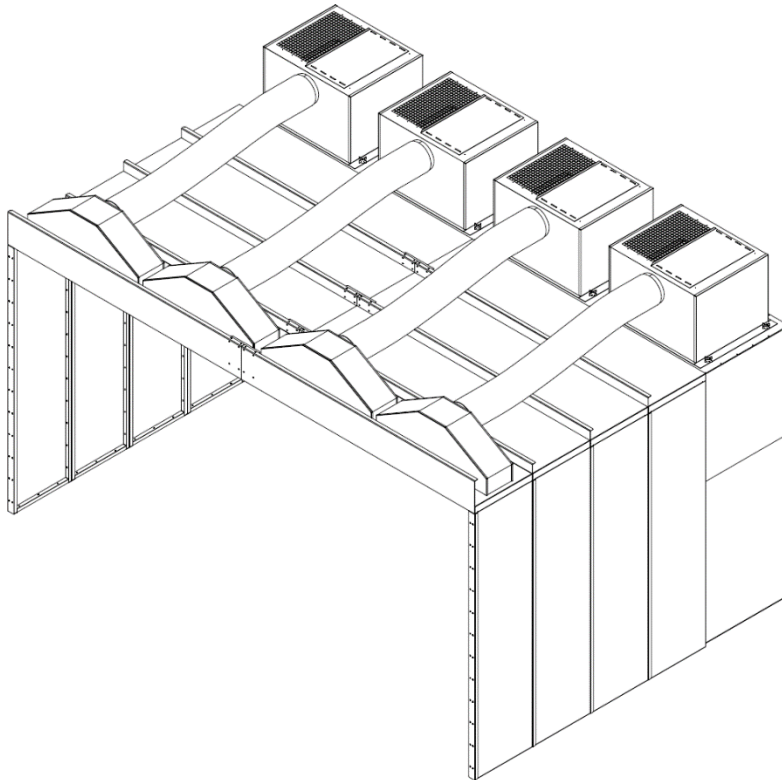

CABIN4-1688 & CABUN4-1688

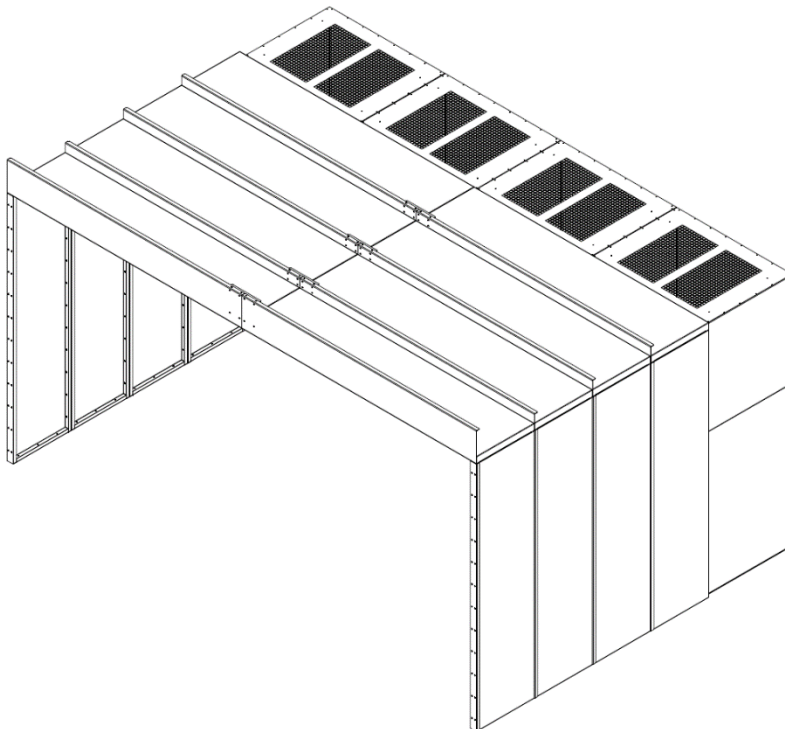



P.O. BOX 1138 • WICHITA, KS. 67201
(316) 943-2351 • FAX (316) 943-2717
INFO@MTLFAB.COM